



18 GHz SMA LATCHING S.P.5 T. SWITCH

OPTIONS : INDICATOR /SELF CUT-OFF /AUTO RESET / TTL DRIVE /SUPP.DIODES

R F CHARACTERISTICS

NUMBER OF WAYS : 5
 FREQUENCY RANGE : 0 - 18 GHz
 IMPEDANCE : 50 Ohms

FREQUENCY (GHz)	0 - 3	3 - 8	8 -12.4	12.4- 18
V.S.W.R <=	1.20	1.30	1.40	1.50
INSERT. LOSS <=	0.20 dB	0.30 dB	0.40 dB	0.50 dB
ISOLATION >=	80 dB	70 dB	60 dB	60 dB
AVER. POWER (*)	120 W	80 W	60 W	50 W

ELECTRICAL CHARACTERISTICS

ACTUATOR : LATCHING
 NOMINAL CURRENT AT 25° C (±10%) : 960 mA
 ACTUATOR VOLTAGE (Vcc) : 12V (10.2 to 13V) / NEGATIVE COMMON
 TERMINALS : 25 pins D-SUB male connector
 INDICATOR RATING : 1 W / 30 V / 100 mA
 SELF CUT-OFF TIME : 40 ms < CT < 120 ms
 TTL INPUTS (E) - High level : 2.2 to 5.5V / 800µA at 5V
 - Low level : 0 to 0.8V / 20µA at 0.8V

MECHANICAL CHARACTERISTICS

CONNECTORS : SMA female per MIL C 39012
 LIFE : 5.000.000 cycles per position
 SWITCHING TIME (nominal voltage;25° C) : < 40 ms
 CONSTRUCTION : splashproof
 WEIGHT : < 220 g

ENVIRONMENTAL CHARACTERISTICS

OPERATING TEMPERATURE RANGE (°C) : -40 , +85
 STORAGE TEMPERATURE RANGE (°C) : -55 , +85

(* : average power at 25° C per RF path)

4112-9212 This information is given as an indication. In the continual goal to improve our products, we reserve the right to make any modifications judged necessary

DRAWING

General tolerance: ± 0,5 mm

R573 492525

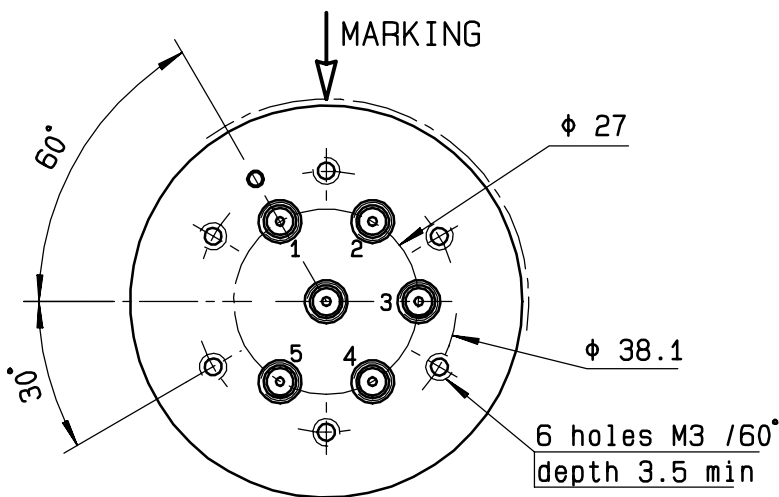

TTL input	RF continuity	Ind.
E1 = 1	IN ↔ 1	D.E
E2 = 1	IN ↔ 2	D.F
E3 = 1	IN ↔ 3	D.G
E4 = 1	IN ↔ 4	D.H
E5 = 1	IN ↔ 5	D.I

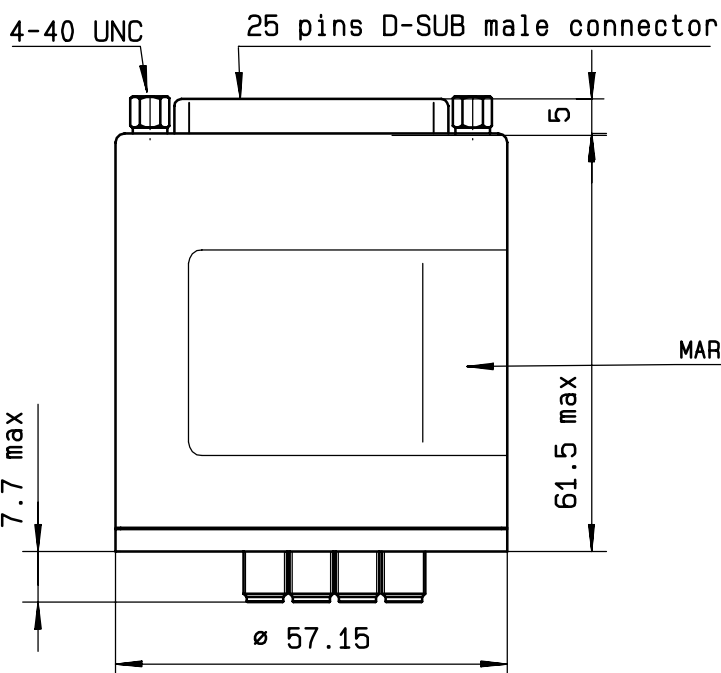

MARKING TOP VIEW (TERMINALS)

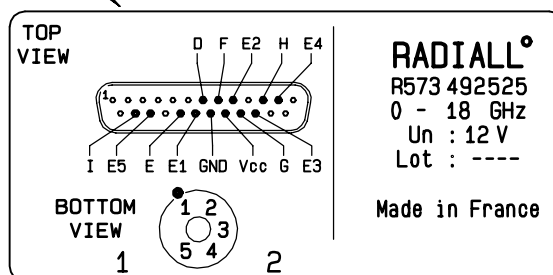

SCHEMATIC DIAGRAM

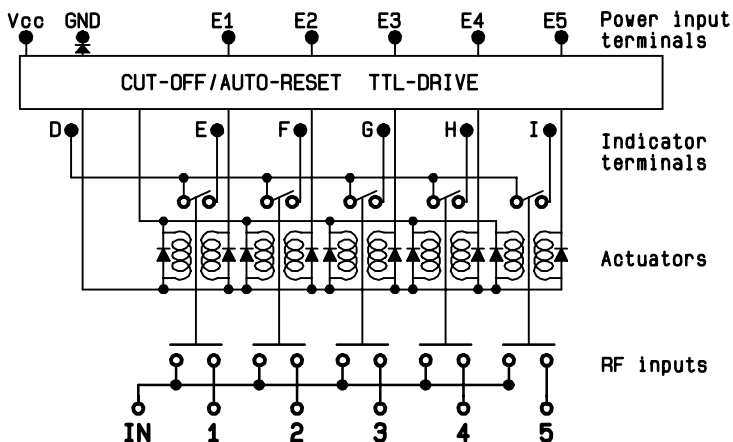

4113-9212 This information is given as an indication. In the continual goal to improve our products, we reserve the right to make any modifications judged necessary